

LVD STYLE

Press brake tooling and equipment



Ashmores are the UK's longest established Press Brake Tool manufacturer established in 1919. We offer Press Brake Tooling to suit all models of press brake: the range includes tools to suit all Euro style machines, Trumpf / Wila, Bystronic, LVD and many more. Large stocks are held where we can offer an immediate response to urgent orders. We can also offer technical advice and back up from our design team. In addition we are able to offer Guillotine Blades for all machines together with a re-grinding service. Our aim is to offer all customers an economical solution to their bending problems with quick response time and deliveries.



LVD

PUNCHES	5
• Standard Lengths	5
• Modifications on request	6
• CV LVD/W 78°.....	7
• CV GI LVD/W 78°	7
• CV LVD/W 26°.....	8
• Punch LVD/W 26°	8
• Hemming Punch LVD/W 20°	8
 DIES	 9
• Standard Lengths	9
• Modifications on request	10
• CV LVD/W H 90 mm - 78°	11
• CV LVD/W H 130 mm - 78°	14
• CV LVD/W H 90 mm - 30°	18
• CV LVD/W H 130 mm - 30°	20
• CV LVD/W H 90 mm - 20°	22

AIR BENDING FORCE CALCULATION

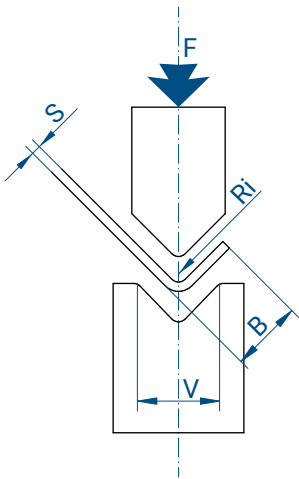

S	Sheet metal thickness - mm	Ri	Inside radius
V	V-opening	R	Aluminium 20-25 kg/mmq
F	Force in T/m	R	Mild steel 40-45 kg/mmq
B	Shortest edge	R	Stainless steel 65-70 kg/mmq

$$F = \frac{S^2 \times 2 \times R}{1.4 \times V} = \dots \text{ ton/m}$$

SHEET METAL THICKNESS / V-SHAPE WIDTH RATIO

S	Sheet metal thickness - mm	0,5-2,5	3-8	9-10	12 or more
V	"V" width	6 S	8 S	10 S	12 S

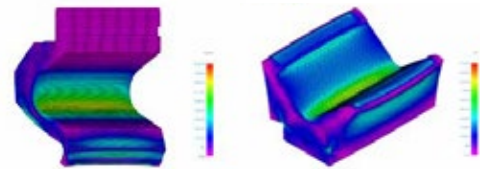

AIR BENDING TABLE - MILD STEEL

S	mm	0,5	0,6	0,8	1	1,2	1,5	2	2,5	3	4	4,5	5	6	8	10	12	15	20	25	30	
6	4	1	3	4	7	11																
8	5,5	1,3	4	5	8	12	20															
10	7	1,6		4	7	10	17															
12	8,5	2			6	8	15	22														
14	10	2,3				7	13	19														
16	11	2,6				6	11	17	28													
18	13,5	3					10	15	25	34												
20	14	3,3					9	13	22	30												
25	17,5	4						11	18	24	43											
32	22	5							14	19	34	44	52									
40	28	6,5								15	27	34	42	60	107							
50	35	8									21	27	33	48	85							
63	45	10										17	21	26	38	68	105					
80	55	13											21	30	53	85	120					
100	71	16												24	43	67	96	150				
125	89	20													53	78	120	215				
160	113	26														42	60	95	170			
200	140	33															55	75	135	210		
250	175	41																108	170	240		
V	B	Ri																				F

t/m

AIR BENDING TABLE - STAINLESS STEEL

S	mm	0,5	0,6	0,8	1	1,2	1,5	2	2,5	3	4	5	6	8	10	12	15	20	25	30		
6	4	1																				
8	5,5	1,3																				
10	7	1,6																				
12	8,5	2																				
16	11	2,6																				
20	14	3,3																				
25	17,5	4																				
32	22	5																				
40	28	6,5																				
50	35	8																				
63	45	10																				
80	55	13																				
100	71	16																				
125	89	20																				
160	113	26																				
200	140	33																				
250	175	41																				
320	226	53																				
V	B	Ri																				F

t/m

STANDARD LENGTHS

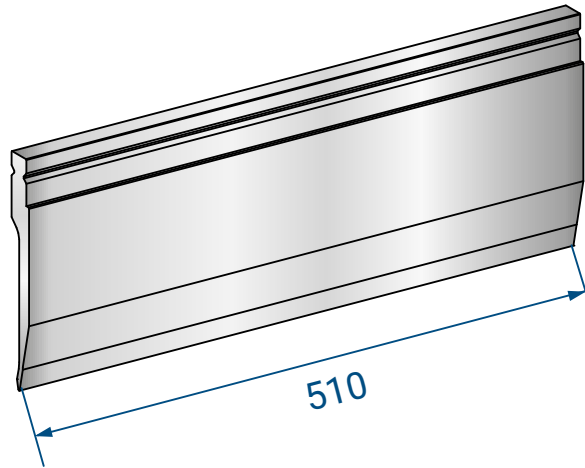
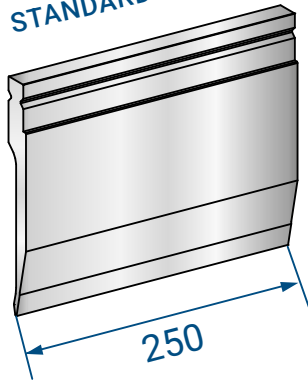

STANDARD SEGMENTATION

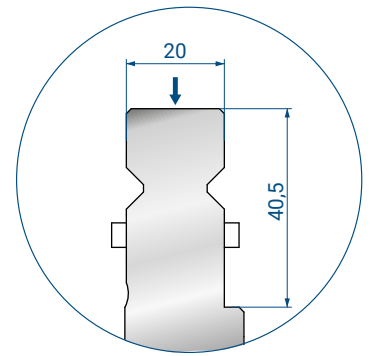
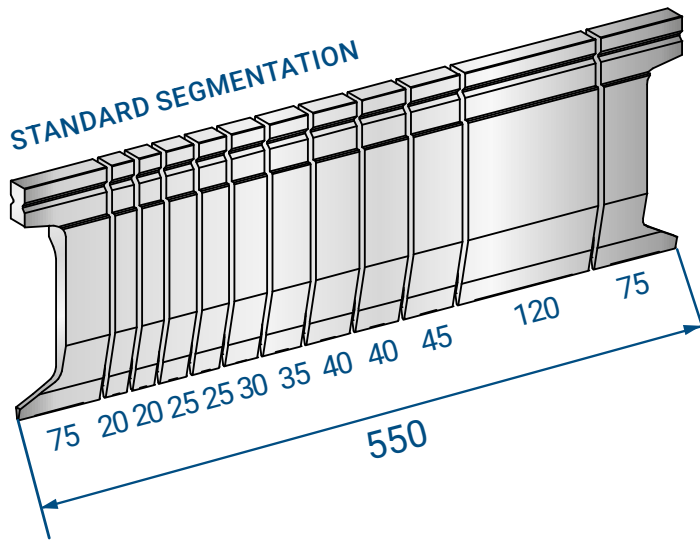

MILLED HORN



THE SAFETY BUTTON IS A STANDARD SUPPLY ON ALL TOOLING UP TO 12.5 KG WEIGH

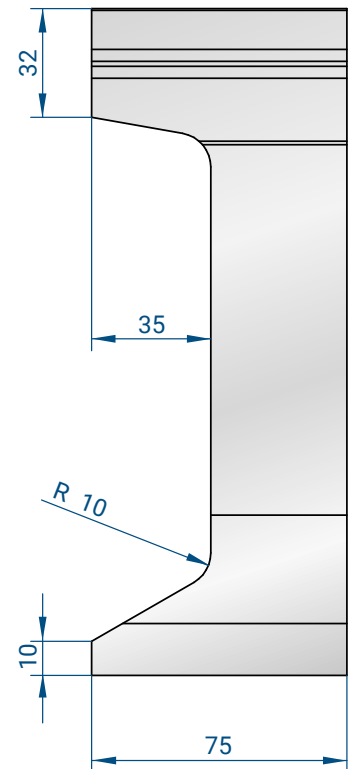

SPECIAL HORNS

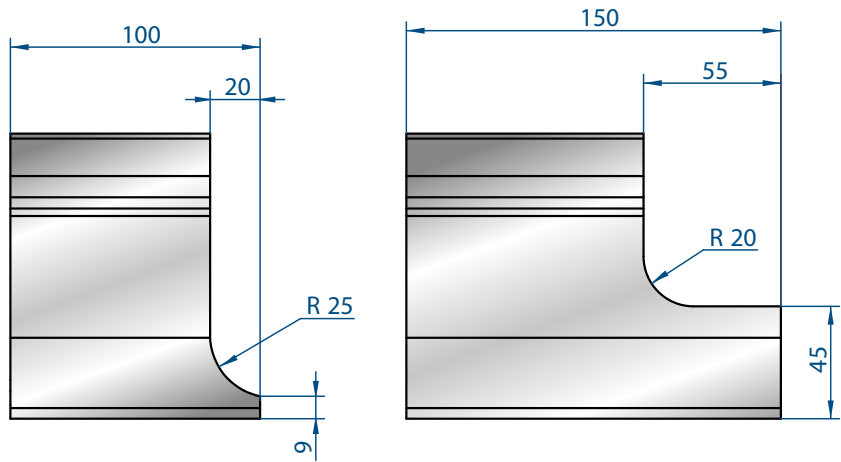

SPECIAL SEGMENTATION



RADIUS MODIFICATION

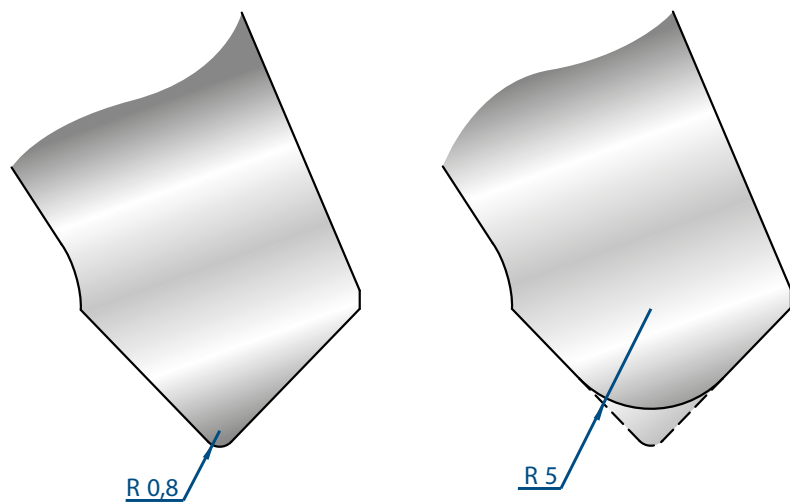

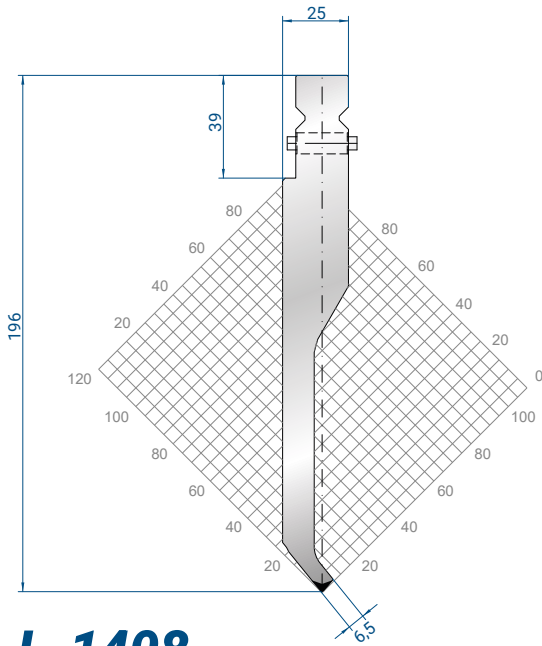

L-1408

Mat = 42CrMo4 •
 H = 196 mm
 Max T/m = 40
 $\alpha = 78^\circ$
 R = 1

510 mm	12,9 kg
250 mm	6,4 kg
550 mm	12,7 kg

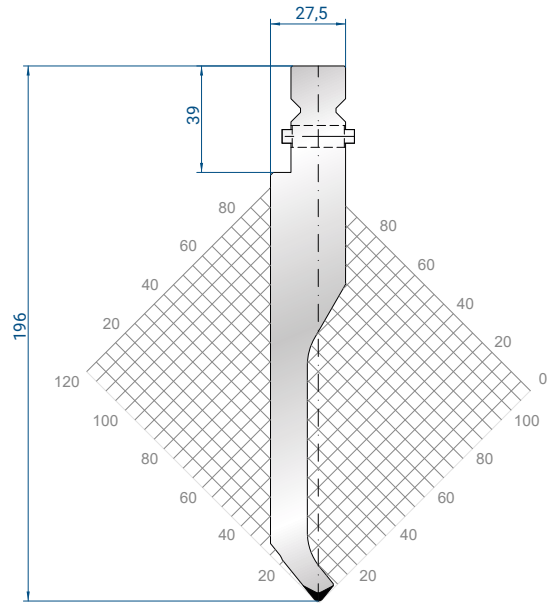

L-1409

Mat = 42CrMo4 •
 H = 196 mm
 Max T/m = 68
 $\alpha = 78^\circ$
 R = 2

510 mm	14,2 kg
250 mm	7,0 kg
550 mm	12,7 kg

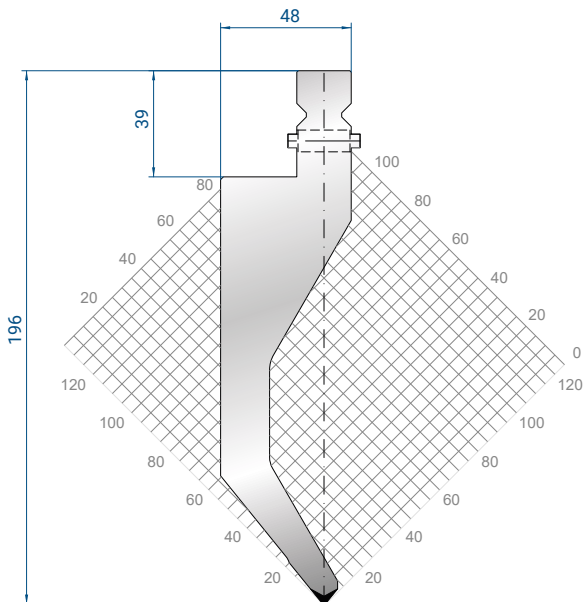

L-1410

Mat = 42CrMo4 •
 H = 196 mm
 Max T/m = 40
 $\alpha = 78^\circ$
 R = 1

510 mm	18,7 kg
250 mm	9,3 kg
550 mm	18,1 kg

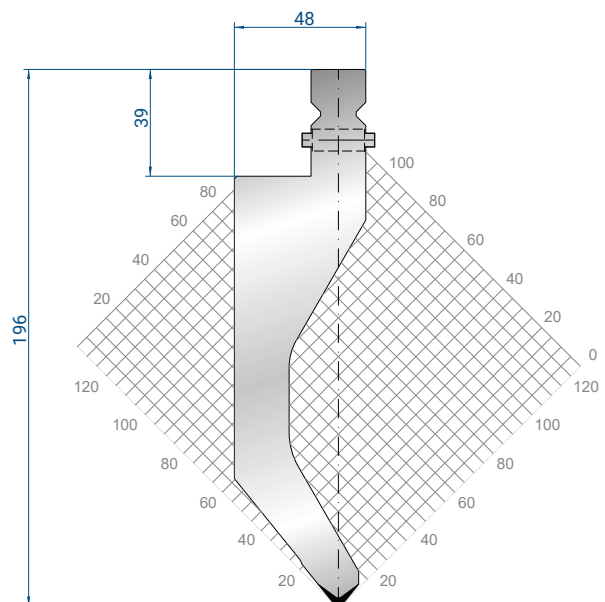

L-1411

Mat = 42CrMo4 •
 H = 196 mm
 Max T/m = 75
 $\alpha = 78^\circ$
 R = 2

510 mm	20,0 kg
250 mm	9,9 kg
550 mm	18,1 kg

PUNCHES - 26°

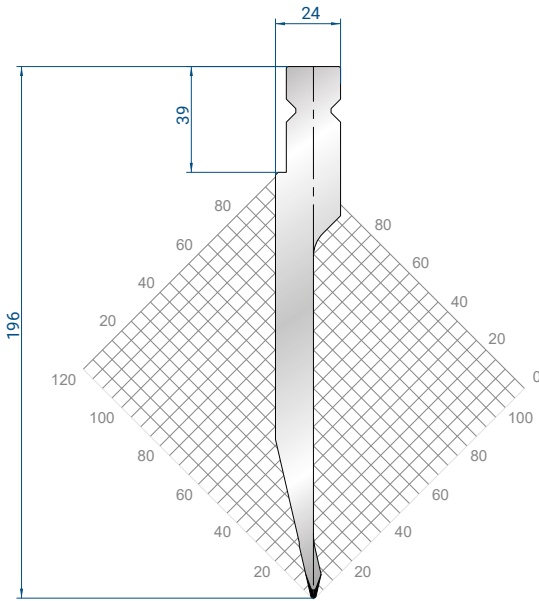

L-1412

Mat = 42CrMo4 •
H = 196 mm
Max T/m = 40
 α = 26°
R = 1

510 mm	11,1 kg
250 mm	5,5 kg
550 mm	19,4 kg

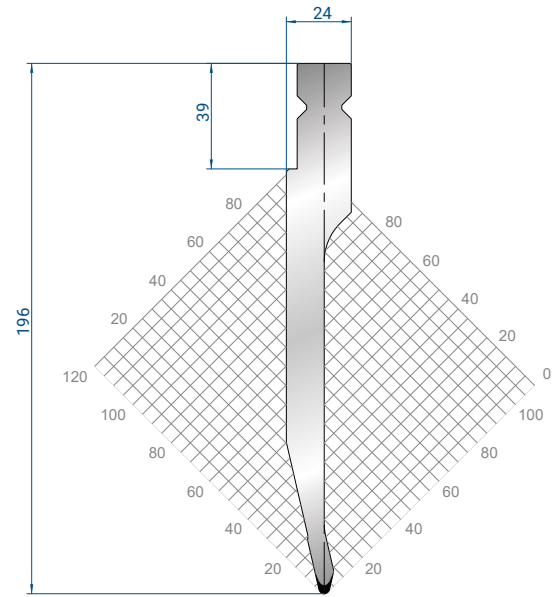

L-1413

Mat = 42CrMo4 •
H = 196 mm
Max T/m = 60
 α = 26°
R = 2

510 mm	11,4 kg
250 mm	5,6 kg
550 mm	11,0 kg

PUNCHES - 20°

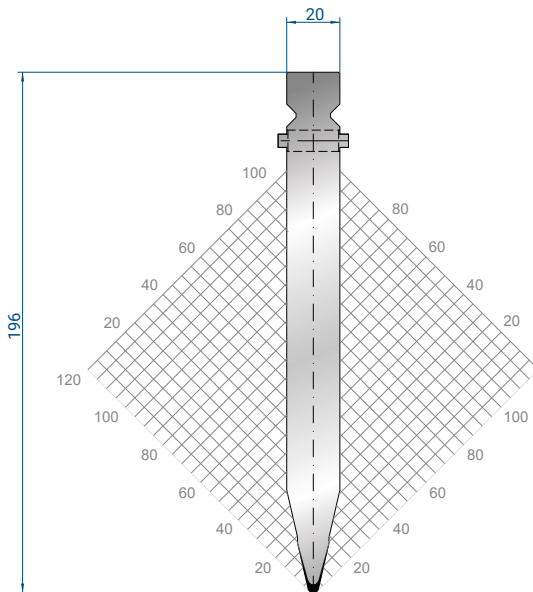

L-1414

Mat = 42CrMo4 •
H = 196 mm
Max T/m = 80
 α = 26°
R = 2

510 mm	14,2 kg
250 mm	7,0 kg
550 mm	13,9 kg

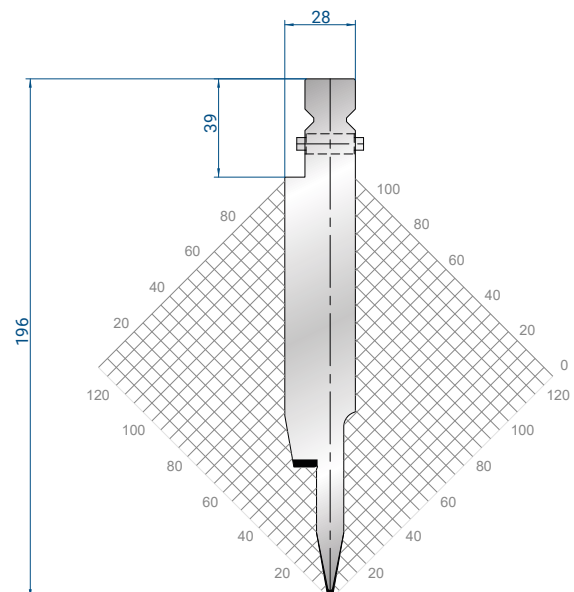

L-1415

Mat = 42CrMo4 •
H = 196 mm
Max T/m = 40
 α = 20°
R = 1

510 mm	17,1 kg
250 mm	8,4 kg
550 mm	13,9 kg

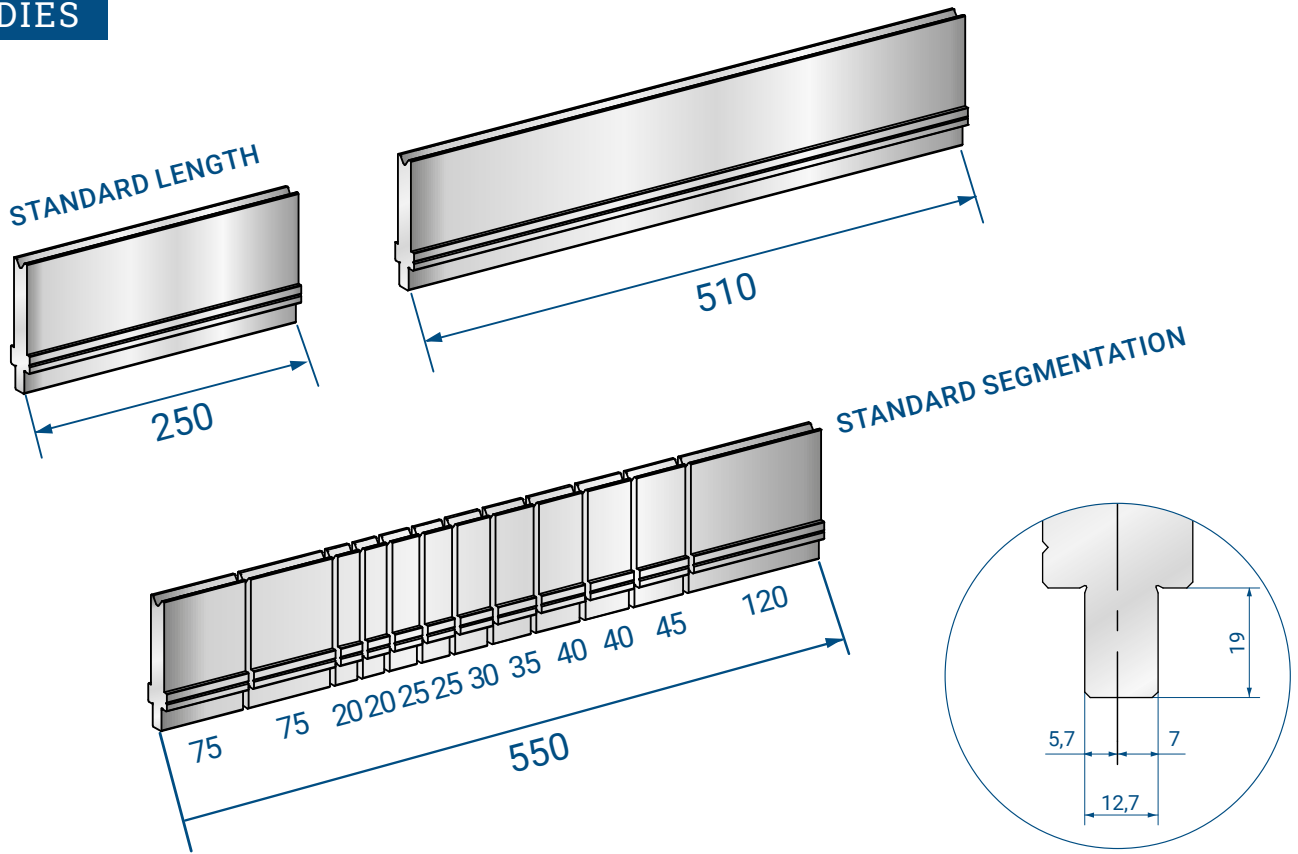

TONNAGE CALCULATED ON 90° BENDS



MODIFICATIONS ON REQUEST

SPECIAL SEGMENTATION

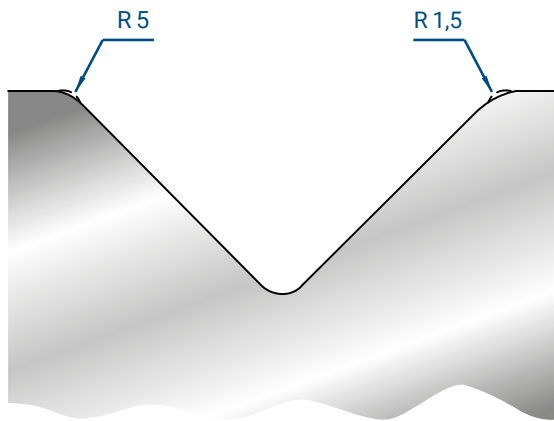
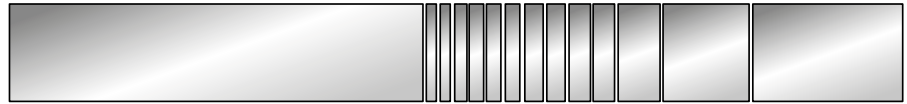

RADIUS MODIFICATION

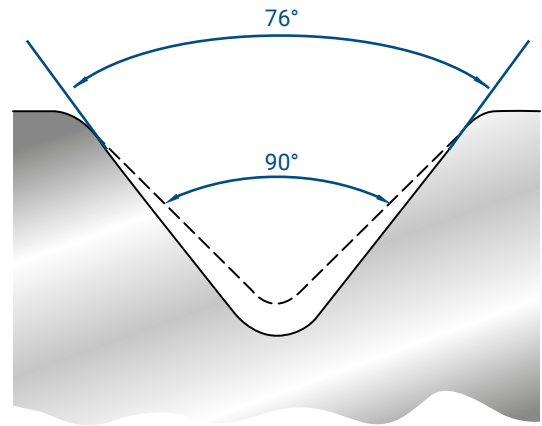

ANGLE MODIFICATION



L-3401

Mat = 42CrMo4 •
 H = 90 mm
 Max T/m = 28
 V = 6 mm
 α = 78°

510 mm	5,5 kg
250 mm	2,7 kg
550 mm	5,9 kg

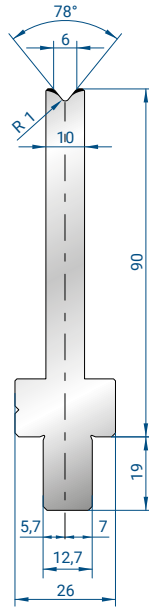

L-3402

Mat = 42CrMo4 •
 H = 90 mm
 Max T/m = 32
 V = 8 mm
 α = 78°

510 mm	6,0 kg
250 mm	3,0 kg
550 mm	6,5 kg

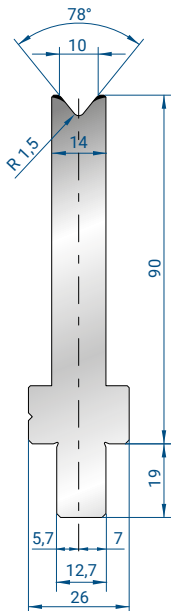
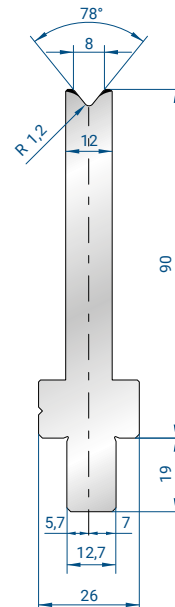

L-3403

Mat = 42CrMo4 •
 H = 90 mm
 Max T/m = 36
 V = 10 mm
 α = 78°

510 mm	6,6 kg
250 mm	3,2 kg
550 mm	7,1 kg

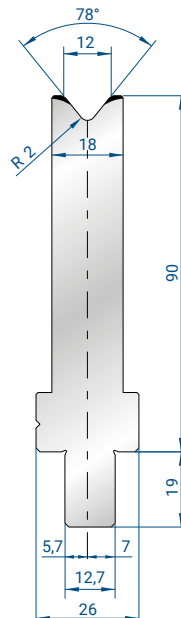

L-3404

Mat = 42CrMo4 •
 H = 90 mm
 Max T/m = 50
 V = 12 mm
 α = 78°

510 mm	7,7 kg
250 mm	3,8 kg
550 mm	8,3 kg

L-3405

Mat = 42CrMo4 •
 H = 90 mm
 Max T/m = 70
 V = 16 mm
 α = 78°

510 mm	9,7 kg
250 mm	4,8 kg
550 mm	10,4 kg

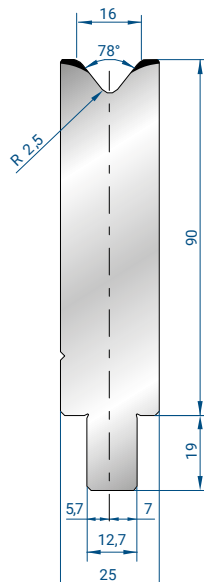

L-3406

Mat = 42CrMo4 •
 H = 90 mm
 Max T/m = 75
 V = 20 mm
 α = 78°

510 mm	11,3 kg
250 mm	5,5 kg
550 mm	12,2 kg

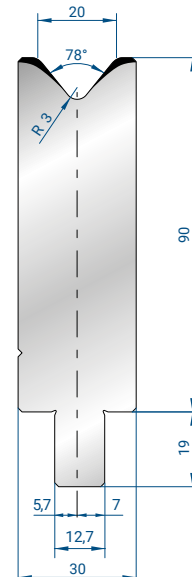

L-3407

Mat = 42CrMo4 •
H = 90 mm
Max T/m = 91
V = 24 mm
 α = 78°

510 mm	11,8 kg
250 mm	5,8 kg
550 mm	12,7 kg

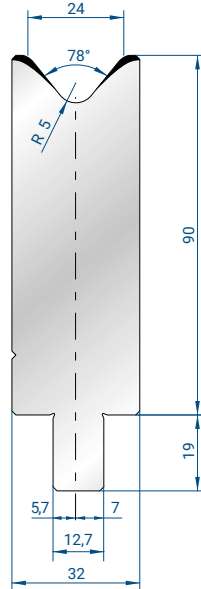

L-3408

Mat = 42CrMo4 •
H = 90 mm
Max T/m = 115
V = 30 mm
 α = 78°

510 mm	14,3 kg
250 mm	7,0 kg
550 mm	15,4 kg

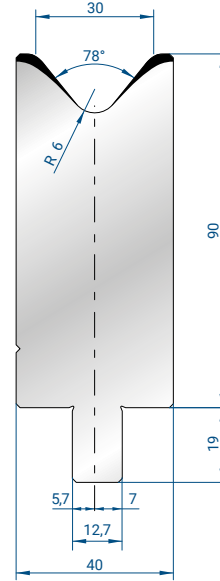

L-3409

Mat = 42CrMo4 •
H = 90 mm
Max T/m = 135
V = 40 mm
 α = 78°

510 mm	17,1 kg
250 mm	8,4 kg
550 mm	18,4 kg

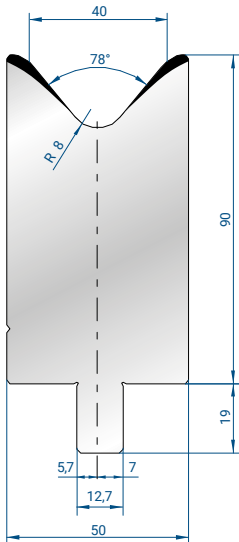

L-3410

Mat = 42CrMo4 •
H = 90 mm
Max T/m = 180
V = 50 mm
 α = 78°

510 mm	21,4 kg
250 mm	10,5 kg
550 mm	23,1 kg

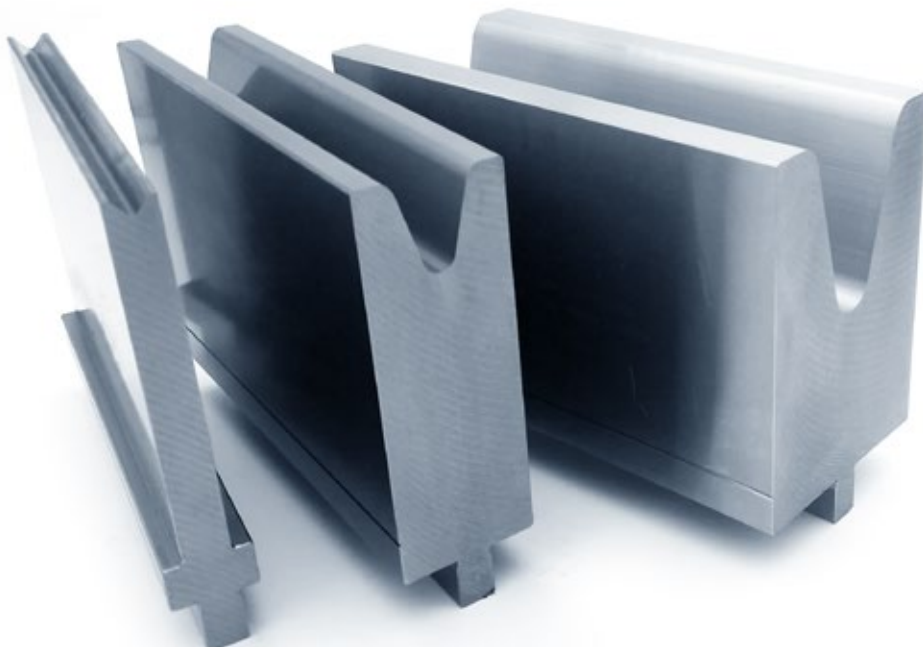
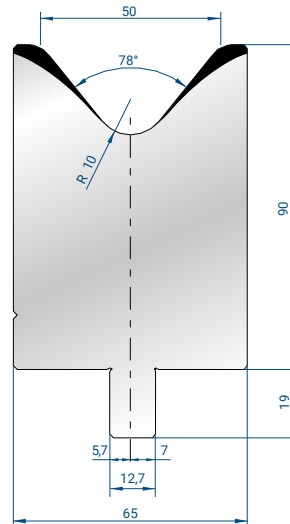

L-3411

Mat = 42CrMo4 •
H = 90 mm
Max T/m = 200
V = 60 mm
α = 78°

510 mm	23,7 kg
250 mm	11,6 kg
550 mm	25,6 kg

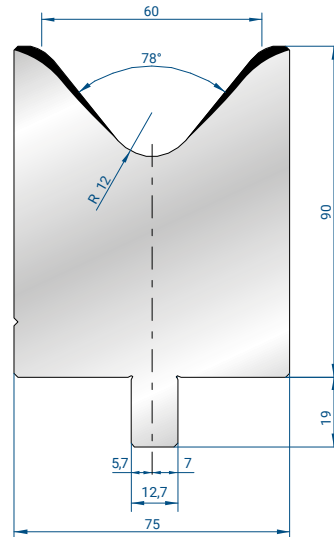

L-3412

Mat = 42CrMo4 •
H = 90 mm
Max T/m = 230
V = 80 mm
α = 78°

510 mm	27,6 kg
250 mm	13,5 kg
550 mm	29,8 kg

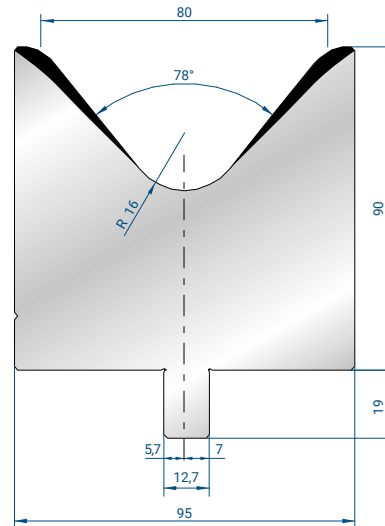

L-3413

Mat = 42CrMo4 •
H = 90 mm
Max T/m = 250
V = 100 mm
α = 78°

510 mm	34,2 kg
250 mm	16,8 kg
550 mm	36,9 kg

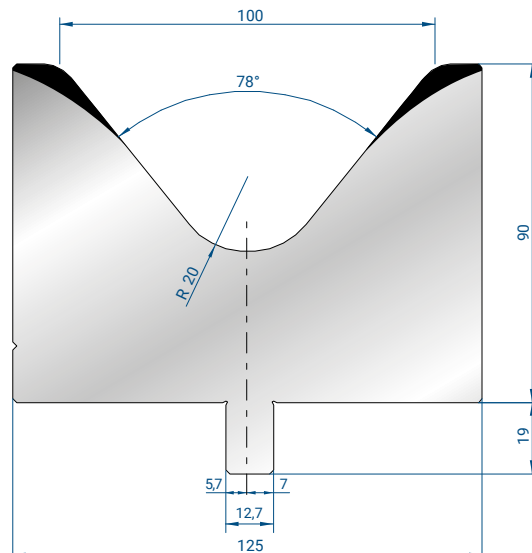

L-3414

Mat = 42CrMo4 •
H = 130 mm
Max T/m = 28
V = 6 mm
α = 78°

510 mm	7,1 kg
250 mm	3,5 kg
550 mm	7,6 kg

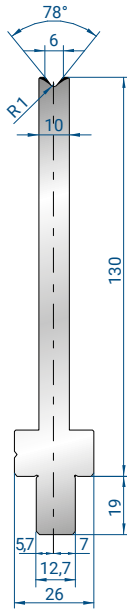

L-3415

Mat = 42CrMo4 •
H = 130 mm
Max T/m = 32
V = 8 mm
α = 78°

510 mm	8,0 kg
250 mm	3,9 kg
550 mm	8,6 kg

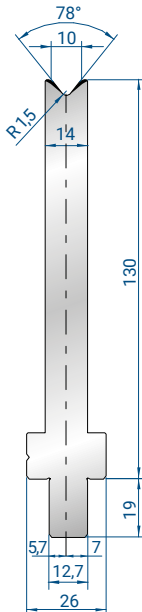
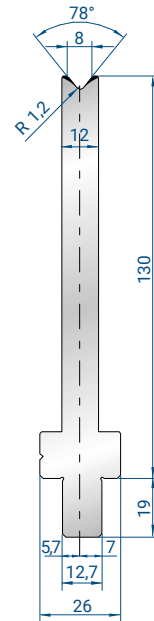

L-3416

Mat = 42CrMo4 •
H = 130 mm
Max T/m = 36
V = 10 mm
α = 78°

510 mm	8,8 kg
250 mm	4,3 kg
550 mm	9,5 kg

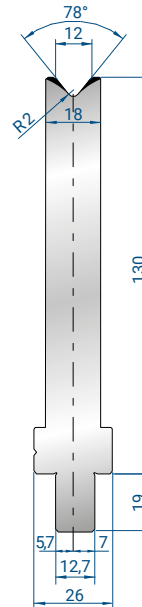

L-3417

Mat = 42CrMo4 •
H = 130 mm
Max T/m = 50
V = 12 mm
α = 78°

510 mm	10,6 kg
250 mm	5,2 kg
550 mm	11,4 kg

L-3418

Mat = 42CrMo4 •
H = 130 mm
Max T/m = 70
V = 16 mm
α = 78°

510 mm	13,7 kg
250 mm	6,7 kg
550 mm	14,8 kg

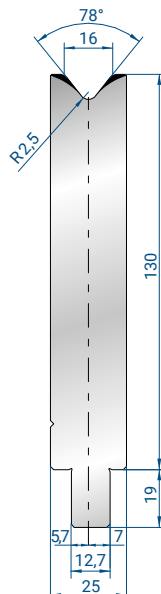

L-3419

Mat = 42CrMo4 •
H = 130 mm
Max T/m = 75
V = 20 mm
α = 78°

510 mm	16,1 kg
250 mm	7,9 kg
550 mm	17,4 kg

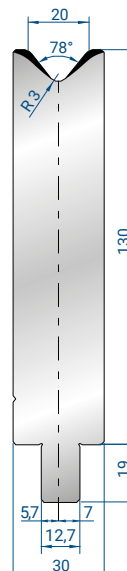

L-3420

Mat = 42CrMo4 •
 H = 130 mm
 Max T/m = 91
 V = 24 mm
 $\alpha = 78^\circ$

510 mm	16,9 kg
250 mm	8,3 kg
550 mm	18,2 kg

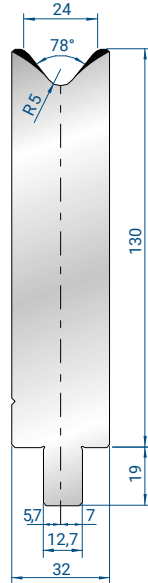

L-3421

Mat = 42CrMo4 •
 H = 130 mm
 Max T/m = 115
 V = 30 mm
 $\alpha = 78^\circ$

510 mm	20,7 kg
250 mm	10,1 kg
550 mm	22,3 kg

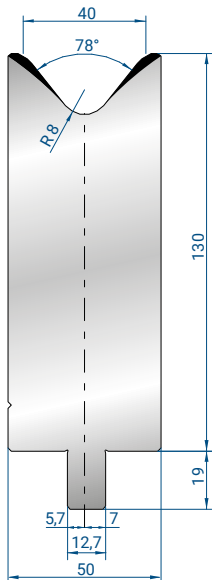
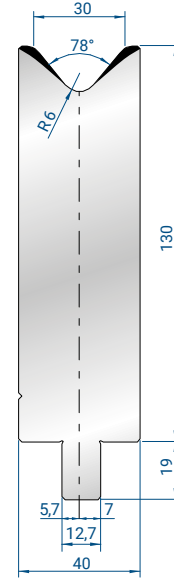

L-3422

Mat = 42CrMo4 •
 H = 130 mm
 Max T/m = 135
 V = 40 mm
 $\alpha = 78^\circ$

510 mm	25,1 kg
250 mm	12,3 kg
550 mm	27,1 kg

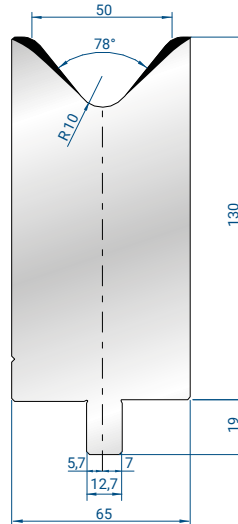

L-3423

Mat = 42CrMo4 •
 H = 130 mm
 Max T/m = 180
 V = 50 mm
 $\alpha = 78^\circ$

510 mm	31,8 kg
250 mm	15,6 kg
550 mm	34,3 kg

L-3424

Mat = 42CrMo4 •
 H = 130 mm
 Max T/m = 200
 V = 60 mm
 $\alpha = 78^\circ$

510 mm	35,7 kg
250 mm	17,5 kg
550 mm	38,5 kg

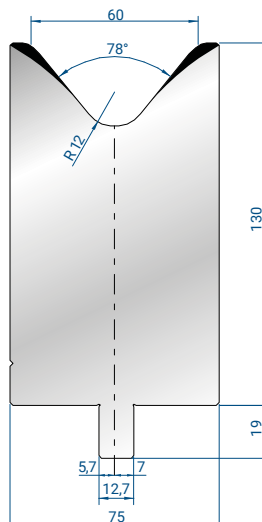

L-3425

Mat = 42CrMo4 •
H = 130 mm
Max T/m = 230
V = 80 mm
 α = 78°

510 mm	42,8 kg
250 mm	21,0 kg
550 mm	46,2 kg

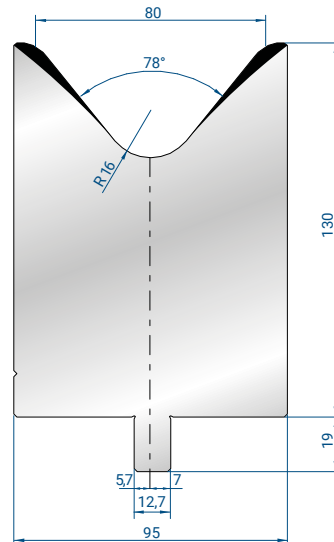

L-3426

Mat = 42CrMo4 •
H = 130 mm
Max T/m = 340
V = 100 mm
 α = 78°

510 mm	54,2 kg
250 mm	26,6 kg
550 mm	58,5 kg

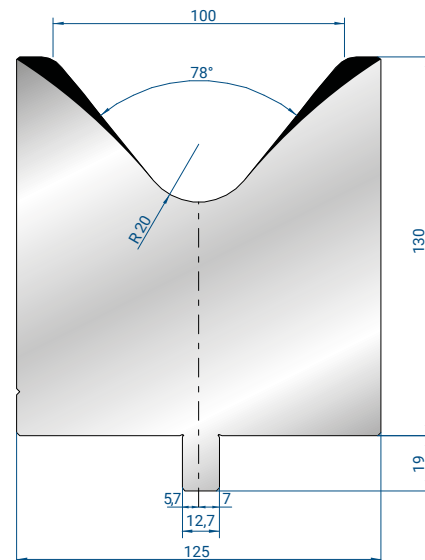

L-3427

Mat = 42CrMo4 •
H = 130 mm
Max T/m = 270
V = 120 mm
 α = 78°

510 mm	56,4 kg
250 mm	27,6 kg
550 mm	60,8 kg

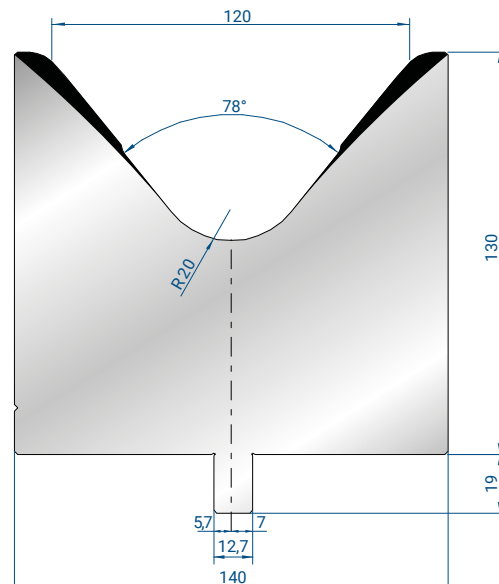

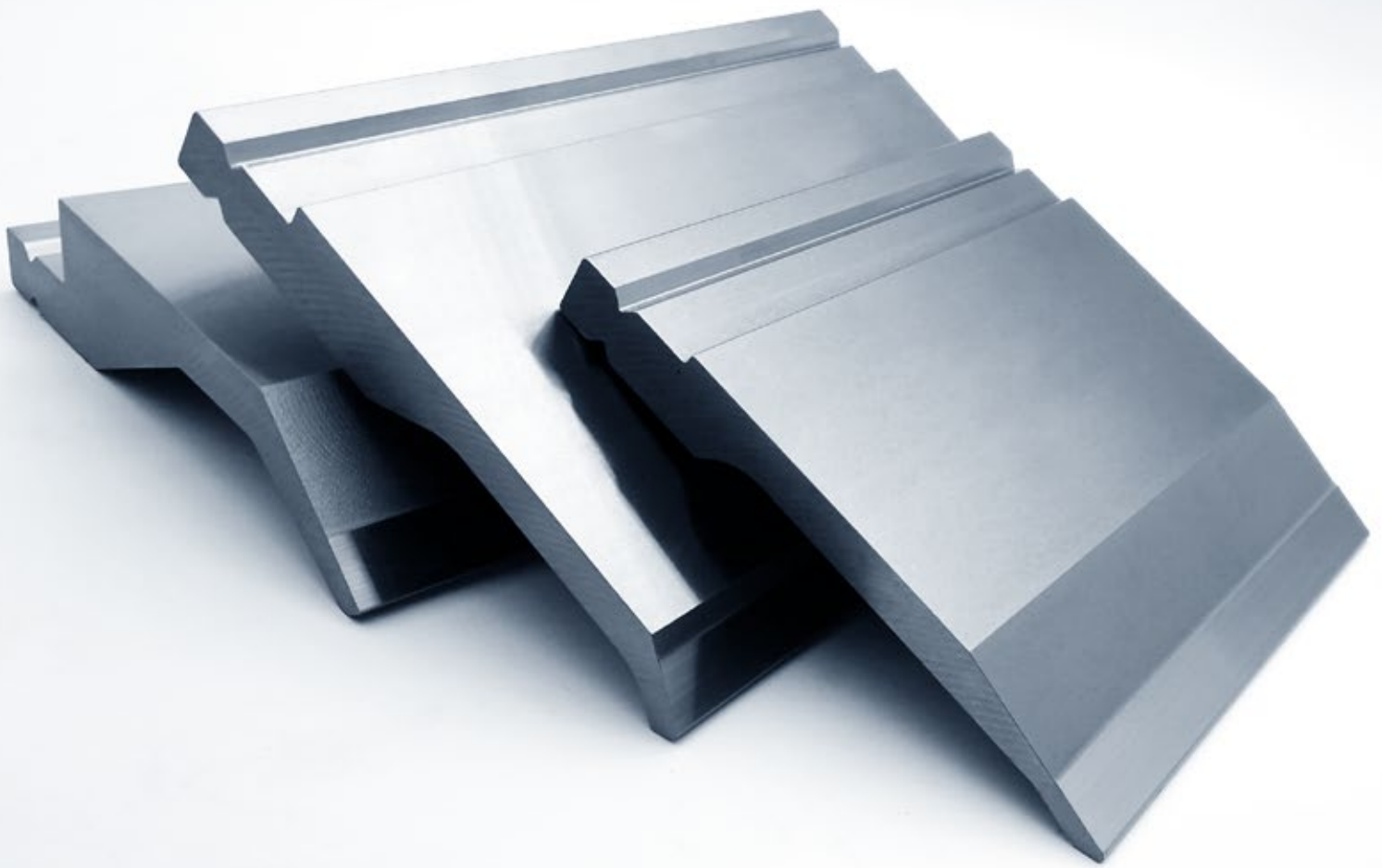

L-3428

Mat = 42CrMo4 •
 H = 90 mm
 Max T/m = 25
 V = 6 mm
 $\alpha = 30^\circ$

510 mm	6,6 kg
250 mm	3,2 kg
550 mm	7,1 kg

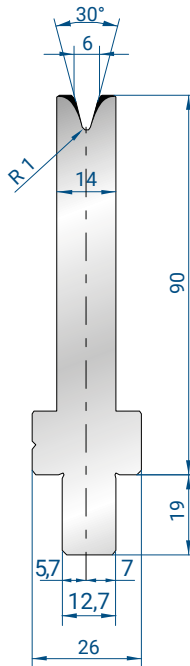

L-3429

Mat = 42CrMo4 •
 H = 90 mm
 Max T/m = 26
 V = 8 mm
 $\alpha = 30^\circ$

510 mm	7,1 kg
250 mm	3,5 kg
550 mm	7,7 kg

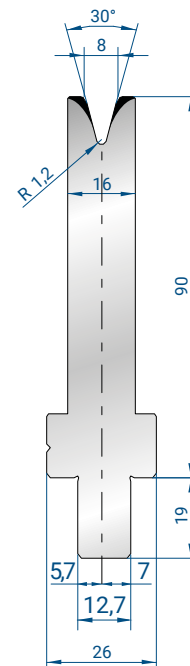

L-3430

Mat = 42CrMo4 •
 H = 90 mm
 Max T/m = 36
 V = 10 mm
 $\alpha = 30^\circ$

510 mm	8,8 kg
250 mm	4,3 kg
550 mm	9,5 kg

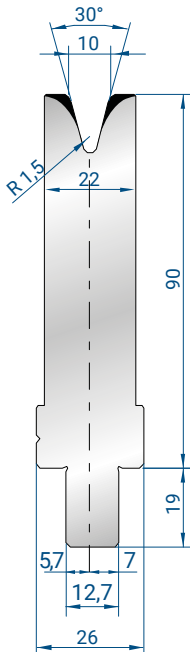

L-3431

Mat = 42CrMo4 •
 H = 90 mm
 Max T/m = 46
 V = 12 mm
 $\alpha = 30^\circ$

510 mm	9,8 kg
250 mm	4,8 kg
550 mm	10,6 kg

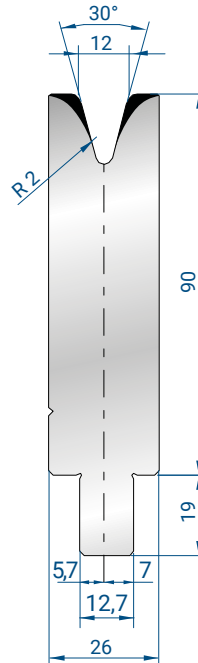

L-3432

Mat = 42CrMo4 •
 H = 90 mm
 Max T/m = 51
 V = 16 mm
 $\alpha = 30^\circ$

510 mm	10,9 kg
250 mm	5,3 kg
550 mm	11,7 kg

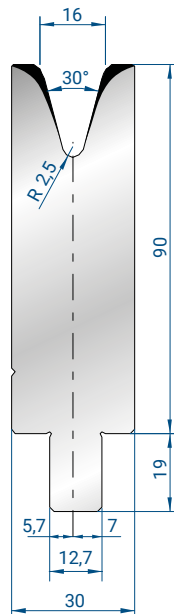

L-3433

Mat = 42CrMo4 •
 H = 90 mm
 Max T/m = 68
 V = 20 mm
 $\alpha = 30^\circ$

510 mm	13,9 kg
250 mm	6,8 kg
550 mm	15,0 kg

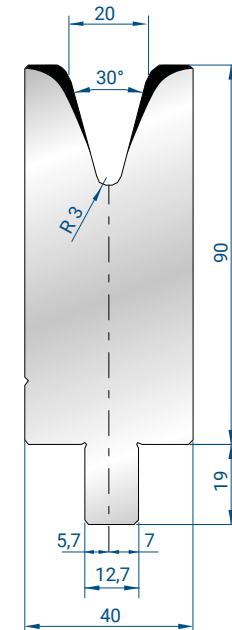

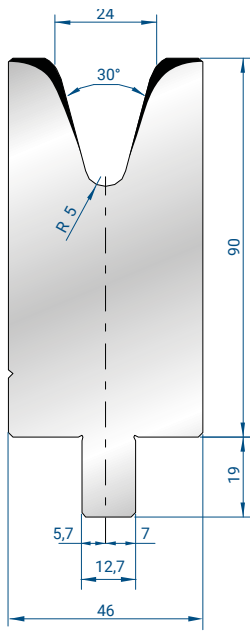

L-3434

Mat = 42CrMo4 •
H = 90 mm
Max T/m = 93
V = 24 mm
 α = 30°

510 mm	15,6 kg
250 mm	7,6 kg
550 mm	16,8 kg

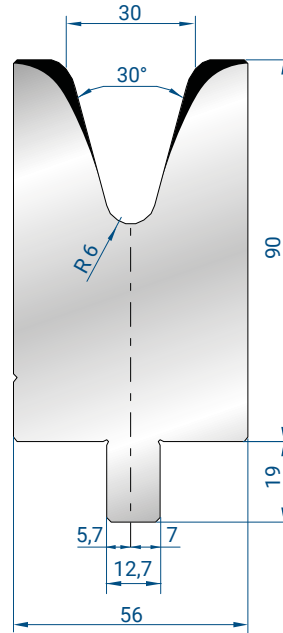

L-3435

Mat = 42CrMo4 •
H = 90 mm
Max T/m = 110
V = 30 mm
 α = 30°

510 mm	18,1 kg
250 mm	8,9 kg
550 mm	19,5 kg

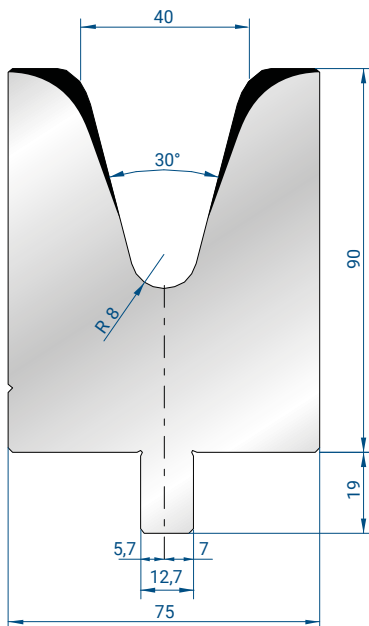

L-3436

Mat = 42CrMo4 •
H = 90 mm
Max T/m = 140
V = 40 mm
 α = 30°

510 mm	22,5 kg
250 mm	11,0 kg
550 mm	24,3 kg

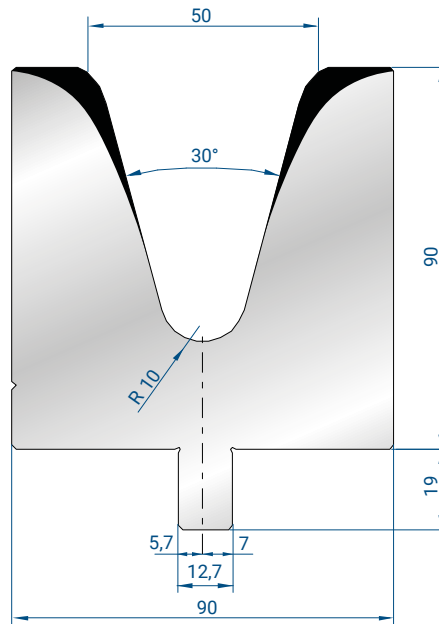

L-3437

Mat = 42CrMo4 •
H = 90 mm
Max T/m = 135
V = 50 mm
 α = 30°

510 mm	24,9 kg
250 mm	12,2 kg
550 mm	27,0 kg

L-3438

Mat = 42CrMo4 •
 H = 130 mm
 Max T/m = 25
 V = 6 mm
 $\alpha = 30^\circ$

510 mm	8,8 kg
250 mm	4,3 kg
550 mm	9,5 kg

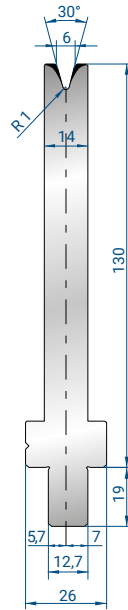

L-3439

Mat = 42CrMo4 •
 H = 130 mm
 Max T/m = 26
 V = 8 mm
 $\alpha = 30^\circ$

510 mm	9,7 kg
250 mm	4,7 kg
550 mm	10,4 kg

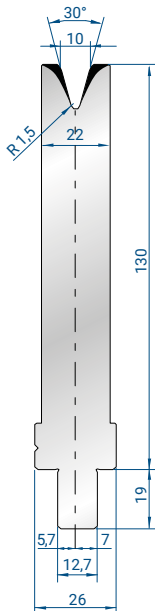
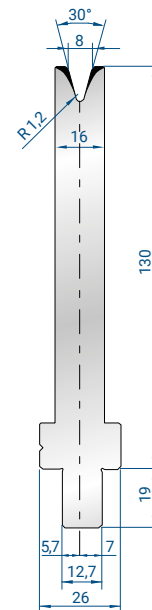

L-3440

Mat = 42CrMo4 •
 H = 130 mm
 Max T/m = 36
 V = 10 mm
 $\alpha = 30^\circ$

510 mm	12,3 kg
250 mm	6,0 kg
550 mm	13,3 kg

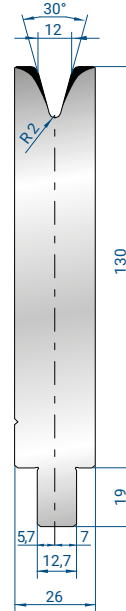

L-3441

Mat = 42CrMo4 •
 H = 130 mm
 Max T/m = 46
 V = 12 mm
 $\alpha = 30^\circ$

510 mm	14,0 kg
250 mm	6,9 kg
550 mm	15,1 kg

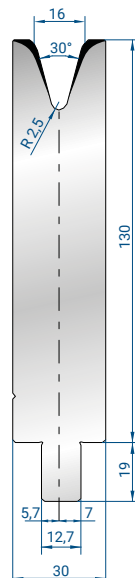

L-3442

Mat = 42CrMo4 •
 H = 130 mm
 Max T/m = 51
 V = 16 mm
 $\alpha = 30^\circ$

510 mm	15,7 kg
250 mm	7,7 kg
550 mm	16,9 kg

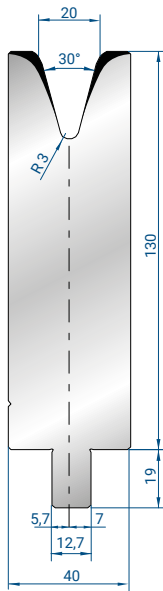

L-3443

Mat = 42CrMo4 •
H = 130 mm
Max T/m = 68
V = 20 mm
α = 30°

510 mm	20,3 kg
250 mm	10,0 kg
550 mm	21,9 kg

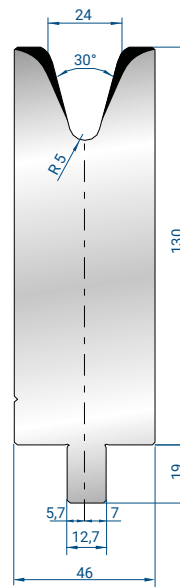

L-3444

Mat = 42CrMo4 •
H = 130 mm
Max T/m = 93
V = 24 mm
α = 30°

510 mm	23,0 kg
250 mm	11,3 kg
550 mm	24,8 kg

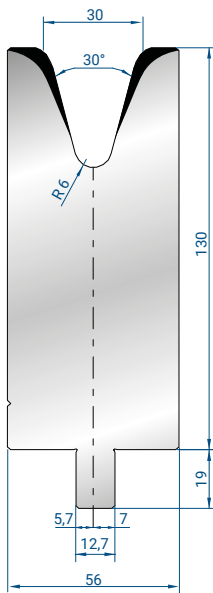

L-3445

Mat = 42CrMo4 •
H = 130 mm
Max T/m = 110
V = 30 mm
α = 30°

510 mm	27,0 kg
250 mm	13,3 kg
550 mm	29,2 kg

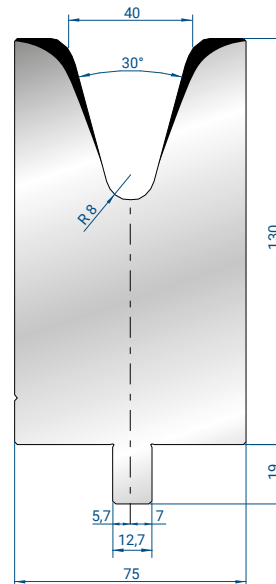

L-3446

Mat = 42CrMo4 •
H = 130 mm
Max T/m = 140
V = 40 mm
α = 30°

510 mm	34,6 kg
250 mm	16,9 kg
550 mm	37,3 kg

L-3447

Mat = 42CrMo4 •
H = 130 mm
Max T/m = 170
V = 50 mm
 α = 30°

510 mm	39,4 kg
250 mm	19,3 kg
550 mm	42,4 kg

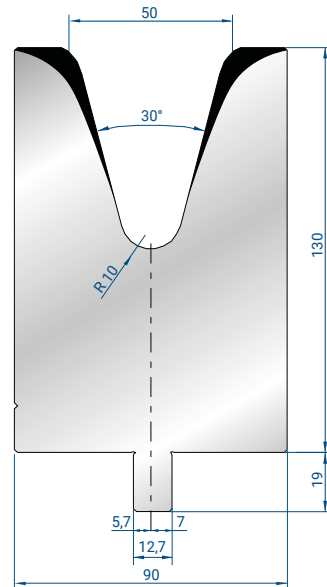

L-3448

Mat = 42CrMo4 •
H = 130 mm
Max T/m = 155
V = 60 mm
 α = 30°

510 mm	37,9 kg
250 mm	18,6 kg
550 mm	40,9 kg

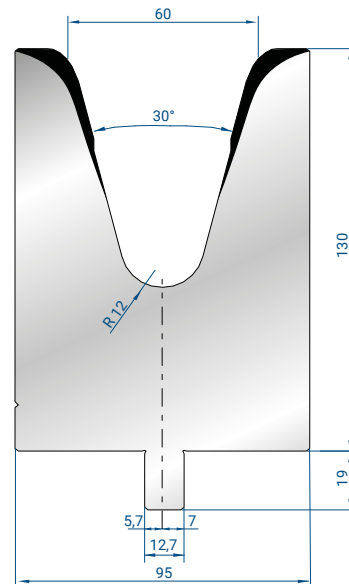

DIES H 90 mm - 20°

L-3449 available upon request

Mat = 42CrMo4 •
H = 90 mm
Max T/m = 21
V = 12 mm
 α = 20°

510 mm	14,6 kg
250 mm	7,15 kg
550 mm	15,75 kg

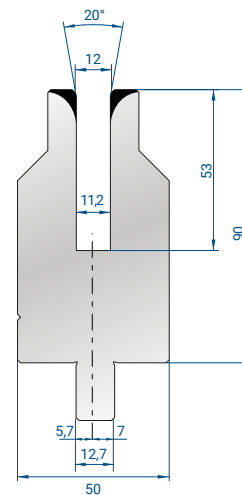





Ashmores Press Brake Tooling LTD
Lewis Street, Great Bridge, Tipton, West Midlands.
DY4 7EF UK

+44 (0) 121 557 1064
+44 (0) 121 557 1085
ashmores@pressbraketool.co.uk